

**CITY OF ST JOSEPH  
RULES AND REGULATIONS OF  
CITY-OWNED CEMETERIES  
(Riverview, City and Highland)**

The Cemetery Board of Trustees has established rules and regulations which in its opinion will afford maximum protection to the burial rights holders and best insure and preserve the beauty, orderly development and care of the cemeteries. Every purchaser of a cemetery lot or lots is subject to the provisions and requirements of any and all relevant ordinances of the City of St. Joseph and lawful rules and regulations made by the Board of Cemetery Trustees, whether such ordinance, rules and regulations are now in force or hereafter adopted. The City and the Cemetery Board of Trustees reserves the right to make such changes or alterations of the rules and regulations as may from time to time seem necessary. Check with the City Clerk's Office for recent changes.

Your cooperation and adherence to these rules will help to create and preserve the beauty of our City Cemeteries, so that the cemeteries may be a beautiful natural memorial to all those at rest here.

**GENERAL RULES**

1. Receipt of Information. The rules and regulations and other information is available at the City Clerk's Office and the city will assume no responsibility for any information except as it may be transmitted from its duly authorized agents.
2. Cemetery Board. The Cemetery Board meets the last Thursday in the months of February, April, June, August and October. Contact the City Clerk's Office for additional information regarding the meetings of the Cemetery Board.
3. Public on Cemetery Grounds. No person shall be allowed in any cemetery from a period beginning one hour after sunset and continuing to one hour before sunrise, without first securing permission from the City of St. Joseph.
4. Business Hours. The cemeteries maintain no regular office hours on-site. The City Clerk's office is available Monday through Friday from 8:00 a.m. until 5:00 p.m. (except holidays) to receive cemetery inquiries and concerns.
5. Children Under 12 Years of Age. Children under 12 years of age, unless accompanied by adults, are not permitted on cemetery grounds.
6. Advertising in Cemeteries. The placing of signs, notices or advertisements of any kind, peddling or soliciting, and the sale of any commodity in the cemetery are prohibited.
7. Business Activities and Assemblies. No person shall use cemetery grounds for any business activity. Meetings, gatherings or assemblies of any kind in cemeteries are prohibited except as a part of a funeral or memorial service.
8. Vehicles within Cemetery Grounds. All vehicles accessing cemetery grounds must remain on dedicated roadways provided and be kept under complete control at all times.

9. Speed Limits. Speed limit on all cemetery drives shall be as posted.
10. Animals within Cemetery Grounds. Domestic animals may be allowed within the cemetery grounds in accordance with Chapter 7 of the St. Joseph Code of Ordinances. Any person walking a dog or other animal, which deposits excrement on cemetery property, shall immediately remove such excrement and deposit same in a suitable refuse disposal container.
11. Permission for Work and Liability for Damages. No person shall perform any work within any cemetery except with the permission of and in accordance with the directions of the Superintendent of Parks and Grounds. Any person causing damage within a cemetery shall be liable to the City of St. Joseph for such damage. Any person performing work in a cemetery without permission shall be liable to the City of St. Joseph for the cost of restoring the cemetery to the condition that it was in before the work was done.
12. Work for Lot Owners. City of St. Joseph employees are not permitted to work on lots for private compensation while on duty.
13. Prohibited Conduct. No person shall engage in any fight or quarrel, or create a disturbance in any cemetery. No person shall loiter in any cemetery or fail to leave any cemetery after having been directed to do so by cemetery management. No person shall interrupt or disturb any funeral or memorial service.
14. Picking of Flowers, Defacing Memorials. Persons visiting the cemetery or attending funerals are strictly forbidden from picking flowers (wild or cultivated), breaking or injuring any trees, shrubs or plants, or writing upon, defacing or injuring any memorials, fences or other structures within the cemetery grounds.
15. Refuse. No person shall leave any refuse in the cemetery except as deposited in the receptacles provided for the same.

## **LOTS**

16. Lot Ownership. Cemetery lots are sold only for the purpose of burying human dead. The term "Lot, Grave Owner or Deed" is intended to mean and shall be construed as meaning the owner of burial rights, rather than actual ownership of real estate.

The word lot as used herein designates a parcel of land located in the cemetery which bears the identification as "Section, Lot, Space" and conveying the right and privilege of burial, the right to construct monuments and markers and such other privileges and rights, subject to the rules of cemetery now in force, or as they may hereafter be enacted.

17. Columbarium Niche Ownership. The term "Columbarium Niche" refers to above ground burial units for the purpose of burial of human cremation remains. Each unit may hold the ashes of not more than two cremains.

18. Lot/Columbarium Sales. The terms of all lot/columbarium sales will be cash at the time of purchase or in accordance with an approved payment plan authorized by the City Finance Office. Upon payment in full, a Right to Burial will be issued to the owner. No lot/columbarium will be considered sold until full payment has been made. No sale, transfer or assignment of a lot(s) or columbarium or a part of a lot shall be valid without the signature of the Mayor and the City Clerk and the proper recording of such a transaction in the official files of the cemetery.
19. Perpetual Care. No lot will be sold without perpetual care which is included in the cost of each lot. Perpetual care shall include watering and mowing of lots and graves, re- sodding, seeding, filling in sunken graves, or sodding over the surface of graves to the lot level.
20. Perpetual Care Exclusions. Perpetual Care shall not include the watering of flowers or plants that are planted by the lot owner. Perpetual Care shall not include the maintenance, repair or replacement of any marker, memorial, tomb, or mausoleum placed or erected on the lot.
21. Lots on Hold. Lots not paid for will be held for a period of 10 days. After that time the hold will be lifted and the lot may be sold to any interested party.
22. Limit Number of Spaces. The Cemetery Board reserves the right to limit the sale of lots/columbaria for burial purposes and intended burial purposes, and will not knowingly sell lots for investment purposes, and no person shall be allowed to speculate in the purchase and sale of lots.
23. Trading of Lot or Grave Space. Purchasers who wish to change their selection to property of equal or greater value must get approval from the City Clerk's Office. If the selection is to property of greater value, the purchaser will be charged the difference in price between the original purchase and the current cost of their new purchase.
24. Lot Marking. The corners of all lots shall be marked with a concrete post. These posts are set below ground grave level. Lots shall be marked only with lot markers furnished by the Cemetery.

## **BURIALS**

25. Supervision and Charges. The Superintendent of Parks and Grounds or his duly appointed assistant shall supervise all interments. All charges made for grave spaces, burials, entombments, inurnments, removals or other services or activities shall be in accordance with the most recent schedule of charges established by the Cemetery Board. Payment for interment and receipt of a burial permit or cremation certificate will be required at the time of burial.

All graves will be opened and closed by employees of the cemetery and graves will not be reopened for inspection except for official investigations.

26. Funeral Directors. Funeral directors are to contact the City Clerk's Office before definitely establishing the time of a funeral, because in some instances the cemetery already has interment arrangements which will cause a conflict due to location or the proper provision of service. For this reason the cemetery reserves the right to ask for a change in the funeral time so as to best serve the families of the deceased.

27. Burial Orders. The City of St. Joseph will not assume any responsibility for errors in location, in the opening of graves when such orders are given by telephone. Orders by undertakers for the opening of graves will be construed as orders from the lot owner or owners. No interment of any remains other than that of a human being will be permitted.

28. Right to Correct Errors. The City of St. Joseph shall have the right to correct any errors that may be made, either in making interment, disinterment or removal, or in the description, transfer, or conveyance of any interment property, either by canceling such conveyance and substituting and conveying in lieu thereof other interment property of equal value and similar location as nearly as possible or may be selected by the Superintendent of Parks and Grounds, or by refunding the amount of money paid on account of that purchase at the option of the City of St. Joseph.

In the event the error shall involve the interment of remains of any person in such property, the Superintendent of Parks and Grounds, subject to the requirements of state law, shall have the right to remove and re-inter the remains in such other property of equal value and similar location as may be substituted and conveyed in lieu thereof.

29. Burials. The City of St. Joseph reserves the right to refuse any order for interment unless the application for the same is made at least forty-eight (48) hours prior to the burial. Burial vaults must be received at least twenty-four (24) hours prior to the burial.

30. Burial Days. The Cemetery is available for services Monday through Saturday and certain holidays. Saturday and Holiday services shall be by SPECIAL ARRANGEMENT at a specific rate established by the Cemetery Board. There shall be no Sunday burials.

31. Burial Hours. Only one burial will be scheduled at any time during any day.

a. Monday through Friday Burial Times

10:00 a.m.

12:00 p.m.

2:00 p.m.

b. Saturday and Holidays Burial Times

10:00 a.m.

12:00 p.m.

32. Overtime Charges. The working day ends for cemetery personnel at 4:00 p.m. One hour is required for personnel to seal a vault and close a grave site. Therefore, whenever a funeral procession remains on-site past 3:00 p.m., overtime charges shall commence immediately and continue until the grave site has been closed.

33. Holiday Schedule. The cemetery is available for burials on these holidays; burials will be scheduled at 10:00 a.m. or 12:00 p.m.

- Martin Luther King Day
- Presidents Day
- Good Friday
- The day after Thanksgiving
- Christmas Eve
- New Year's Eve

No orders for burials will be accepted on the following recognized holidays:

- New Year's Day
- Memorial Day
- Independence Day
- Labor Day
- Thanksgiving Day
- Christmas Day

34. Maximum Number of Burials. Per single grave site, the maximum number of burials is as follows:

- One (1) full interment and One (1) cremains without a vault on a single grave space
- Two (2) cremains with or without vaults on a single grave space, except in Section 9 (In-ground Cremation Section) which will only accommodate one (1) cremains due to lot size.

35. Vaults. All adult burials in City-owned cemeteries must be made in vaults made of metal, reinforced concrete or other materials approved by the Superintendent of Parks and Grounds. That approval shall be based upon permanency, durability, strength and ability to seal. Burial containers shall be classified as follows:

- Burial outer cases over five (5) feet in length will be classified as adult size
- Oversized vaults are permitted at an additional cost; an "Oversized vault" is any vault larger than the standard size (40"x 96")

36. Vaults Received. All vaults that are used for burials in City-owned cemeteries, must be in place to receive the casket one hour prior to the scheduled time of the funeral service.

37. Interment. Interment in lots for which deeds have been issued shall be restricted to members of the family and relatives of the owner or owners thereof. Special written consent must be given by the owner or owners thereof for interments contrary to this rule.

38. Disinterment. No disinterment of a body will be made until the written consent of the next of kin of the person whose body is to be disinterred and/or all legal documentation has been submitted.

39. Responsibility. The City of St. Joseph will assume no responsibility for any damage that might occur in the placing of a body in any mausoleum or crypt, other than performing the service required with the utmost diligence and care.

40. Funeral Zone. Strangers are asked not to approach a grave during a funeral. When deemed necessary by the Superintendent of Parks and Grounds or cemetery personnel, or upon request of the lot owner or his representative, a funeral zone may be established and no one except persons attending the funeral or so authorized, will be permitted within its boundaries.
41. Funeral Procession. All funeral processions while in the cemetery will be under the supervision and control of the Superintendent of Parks and Grounds and/or cemetery personnel and all funeral processions and cemetery vehicles shall have preference over all other vehicles
42. Orderly and Dignified Manner. All funeral and interments made in City-owned cemeteries are to be conducted in an orderly and dignified manner, and the Superintendent of Parks and Grounds is authorized to take such means, as in his opinion are necessary, to preserve this order and dignity.

### **MONUMENTS AND MARKERS**

43. Headstones. All monuments, headstones, markers or other permanent memorials above ground, or partly above ground, must be constructed of first quality granite or marble. All such materials which are used in memorial work must be guaranteed by the monument dealer to be first grade, clear stone at least four inches in thickness, free from sap or anything which will cause rust stains, that it will not crack or check, and has been executed in first grade workmanship.
44. Foundations. All orders for installation of foundations for memorial work must be submitted on an order form of that monument dealer with full particulars therein. These forms must give all information, as requested, and the material certification must be signed by a responsible party of the person, firm, or corporation ordering the foundation installed. The City of St. Joseph will not be bound to honor these foundation orders for the installation of foundations until these requirements have been satisfied.
  - a. All foundations for memorial work placed in City-owned cemeteries shall be installed by city personnel under the direction of the Superintendent of Parks and Grounds. No monuments, markers, etc., may be placed on a lot before the foundation is installed.
  - b. It is the intent of the cemetery to install foundations at least twice yearly, during the months of May and October or more frequently, depending of demand.
  - c. Foundations will be charged to the person, firm or corporation ordering the foundation installed. All charges for foundations must be paid before foundations are installed. Outside contractors installing foundations are required to meet all cemetery rules.
  - d. All foundations will be installed with the top of the foundation conforming to the lot grade as determined by the cemetery.
45. Memorial Work. All memorial work in City-owned cemeteries must be done during normal cemetery hours or with the prior approval of the Superintendent of Parks and Grounds.
  - a. No monument, marker or other memorial may be removed from a lot or taken from the cemetery without proper notification to the Superintendent of Parks and Grounds.

- b. No monument, double/single marker or other memorial, may be erected on any lot or grave until such lot or grave space is fully paid for and the Right to Burial Certificate issued for same, and until any other charges due are paid in full.
  - c. Graves are to be marked only with standard markers or memorials which comply with the rules and regulations of City-owned cemeteries.
  - d. No burials will be permitted to be marked with a vase, urn, memorial, receptacle, or other article of any nature bearing the name of the mortician, memorial dealer, or any person selling or giving such articles for marking purposes.
  - e. No sand, gravel, washed gravel, crushed stone or other loose material may be used in the construction of washes around the bases of markers or monuments.
  - f. No more than one marker will be allowed on a lot space. Markers or monuments shall not be cemented to the footings.
46. Damage. Any damage to turf, trees, shrubs, flowers or structures, resulting from the delivery or setting of memorial work, will be assessed to the person, firm or corporation selling the memorial work.

#### **CEMETERY MONUMENT SIZE REGULATIONS**

Monument Size and Placement Restrictions. Specific restrictions apply to all foundations, monuments, markers and memorials within each designated section of Riverview Cemetery. All plans and specifications for monuments must be approved by the Deputy Director of Public Works before a foundation order maybe placed. The diagram must include Height, Width & Depth for both the monument and the base (see example diagrams below).

The City of St. Joseph assumes no responsibility for memorial sales which may be made in conflict with these restrictions, nor will the City assume any responsibility for any information transmitted during memorial transactions other than that covered in these official Rules and Regulations, and transmitted by its duly authorized agents. The following is a listing of approved headstone sizes allowed in Riverview Cemetery.

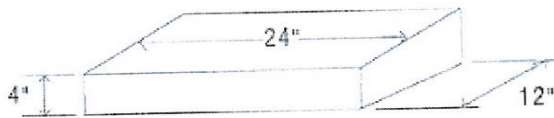
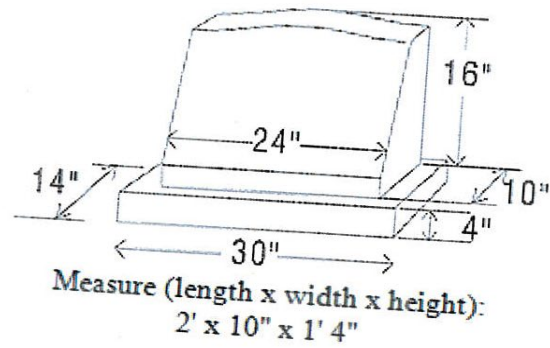
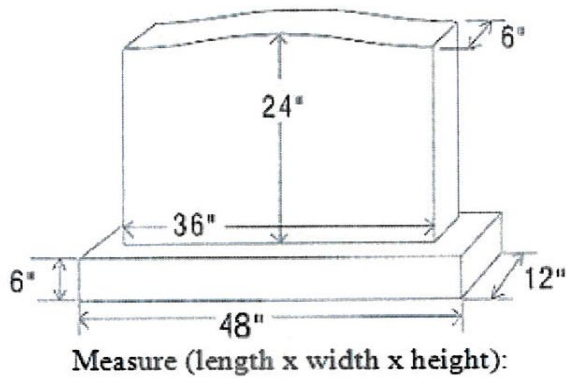

Measure (length x width x height):  
24" x 12" x 6" -OR- 2' x 1' x 6"  
Note: The marker is 2" shorter in the front.

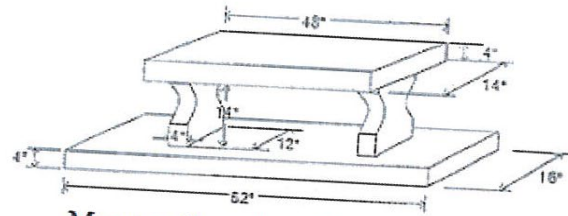

Measure (length x width x height):  
SEAT: 4' x 1' 2" x 4"  
SUPPORT: 1' x 4" x 1' 2"  
BASE: 4' 4" x 1' 4" x 4"

**TOWER SECTION.**

Section A, B, C and D are designated as grass marker sections.  
Size 24 inch x 12 inch flush markers only.

**SECTION 1.**

Single markers - no more than 32 inches long x 14 inches wide and no more than 36 inches tall. Double markers no more than 72 inches long x 14 inches wide and no more than 36 inches tall

**SECTION 2.**

Single Markers - no more than 32 inches long X 14 inches wide X 36 inches tall.  
Monuments and double markers to be no more than 72 inches long and 36 inches tall.

**SECTION 3.**

Lot 14 – 277 - Single markers - no more than 32 inches long X 14 inches wide X 36 inches tall.  
Lot 278 to 905 - Single markers - no more than 24 inches long X 12 inches wide X 16 inches tall.  
Lot 14 – Lot 277 - Monuments and double markers to be no more than 36 inches tall.

**SECTION 4.**

Single markers - no more than 24 inches long X 12 inches wide X 16 inches tall.  
Monuments and double markers to be no more than 36 inches long X 12 inches wide X 16 inches tall.

**SECTION 5.**

Single markers on front of lots - no more than 24 inches long 12 inches wide X 16 inches tall.  
Monuments and double markers on back of lots only - no more than 36 inches tall.

**SECTION 6.**

Single markers - no more than 32 inches long X 14 inches wide X 24 inches tall.  
Monuments and double markers to start at 24 inches and go to 36 inches in center of section.



**SECTION 7.**

Single markers to be no more than 32 inches long X 14 inches wide X 36 inches tall.  
Monuments and double markers no more than 72 inches long and no more than 36 inches tall.

**SECTION 8.**

Single markers - no more than 24 inches long X 12 inches wide X 16 inches tall.  
Monuments and double markers on back of lots only, to be no more than 42 inches tall.

**SECTION 9.**

**INFANT SECTION.**

Size of marker – 16 inches long X 8 inches wide X 8 inches tall.

**VETERAN SECTION.**

Stones are to be upright government marble markers only - 4 inches thick X 13 inches wide X 42 inches tall.

**CREMATION SECTION.**

All Flush Markers only - 24 inches long X 12 inches wide in either bronze or granite.

**SECTION 9.**

Single markers - no more than 32 inches long X 16 inches wide, 24 inches tall in Row 1 & 2 and go to 36 inches in Rows 7 – 9.  
Monuments and double markers no more than 72 inches long and start at 24 inches tall in Row 1 & 2 and go to 36 inches in Rows 7 -9.  
Rows 1 and 2: 24 inches tall  
Rows 3, 4, 5, 6: 30 inches tall  
Rows 7, 8, and 9: 36 inches tall

**SECTION 10.**

Single markers - no more than 32 inches long X 16 inches wide, start at 24 inches tall in Rows 1 & 2 and go to 36 inches in Rows 6 – 8.  
Monuments and double markers no more than 72 inches long and start at 24 inches tall in Rows 1 & 2 and go to 36 inches in Rows 6 – 8.  
Rows 1 and 2: 24 inches tall  
Rows 3, 4, and 5: 30 inches tall  
Rows 6, 7, and 8: 36 inches tall

**SECTION 11.**

Single markers - no more than 32 inches long X 14 inches wide and start at 24 inches tall in Row 1 and go to 42 inches in Rows 7-10.  
Size of Monuments and double markers no more than 72 inches long and start at 24 inches tall in Row 1 and go to 42 inches in Rows 7-10.  
Row 1: 24 inches tall  
Row 2 and 3: 30 inches tall  
Row 4, 5 and 6: 36 inches tall  
Row 7, 8, 9 and 10: 42 inches tall

**SECTION 12.**

Single markers - no more than 32 inches long X 14 inches wide X 24 inches tall in Row 1 and go to 42 inches in Rows 7-10.

Size of Monuments and double markers no more than 72 inches long and start at 24 inches tall in Row 1 and go to 42 inches in Rows 7-10.

Row 1: 24 inches tall

Row 2 and 3: 30 inches tall

Row 4, 5 and 6: 36 inches tall

Row 7, 8, 9 and 10: 42 inches tall

**SECTION 13.**

Single markers - no more than 32 inches long X 14 inches wide X 24 inches tall in Row 1 and go to 42 inches in Rows 7-10.

Size of Monuments and double markers no more than 72 inches long and start at 24 inches tall in Row 1 and go to 42 inches in Rows 7-10.

Row 1: 24 inches tall

Row 2 and 3: 30 inches tall

Row 4, 5 and 6: 36 inches tall

Row 7, 8, 9 and 10: 42 inches tall

**SECTION 14.**

Single Markers to be no more than 32 inches long X 14 inches wide and start at 24 inches tall in Rows 1 and 2 and go to 30 inches in Rows 3-12. Monuments and double markers no more than 72 inches long and start at 24 inches tall in Rows 1 and 2 and go to 30 inches in Rows 3-12.

Row 1 and 2: 24 inches tall.

Row 3, 4, 5, 6, 7, 8, 9, 10, 11 and 12: 30 inches tall.

**SECTION 15.**

Single markers - no more than 32 inches long X 14 inches wide X 24 inches tall in Row 1 and go to 42 inches in Rows 7-10.

Monuments and double markers no more than 72 inches long and start at 24 inches tall in Row 1 and go to 42 inches in Rows 7-10.

Row 1: 24 inches tall.

Row 2 and 3: 30 inches tall.

Row 4, 5 and 6: 36 inches tall.

Row 7, 8, 9 and 10: 42 inches tall.

**SECTION 16.**

Single markers - no more than 32 inches long X 14 inches wide and start at 24 inches tall in Rows 1 & 2 and go to 36 inches in Rows 6-8.

Size of monuments and double markers no more than 72 inches long and start at 24 inches tall in Rows 1 & 2 and go to 36 inches in Rows 6 – 8.

Rows 1 and 2: 24 inches tall

Rows 3, 4, and 5: 30 inches tall

Rows 6, 7, and 8: 36 inches tall

47. Unightly Markers. If any memorial, headstone or marker shall become unsightly, in need of repair or attention, or a menace, the City of St. Joseph will notify by certified mail at last known address, the owner or owners thereof to take such steps as necessary to place the structure in

satisfactory condition. If such owner or owners fail to comply with that notice within a reasonable length of time, the City of St. Joseph shall have the right to cause the necessary repairs to be made and the cost thereof shall be charged to the owner or owners.

The Cemetery Board shall reserve the right to refuse permission for the erection of any memorial which due to size, design, inscription, or kind or quality of stone is in its opinion unsuited to the lot or lots, or the location on which it is to be placed.

The Cemetery Board shall reserve the right to deny the marking of an unused grave.

## **CREMATIONS**

48. Cremation Burials. All cremation burials must be conducted by cemetery personnel. All fees for cremation burials will be paid in accordance with the Cemetery Fee Schedule, as established by the Cemetery Board.
- a. All cremation burials will be conducted during normal cemetery hours. The use of an outside burial container (vault) is optional.
  - b. The cremated remains must be buried or placed within a mausoleum or columbarium. The scattering on the ground is prohibited. Remains may be removed from the transportation container and placed directly in the ground.
  - c. The City of St. Joseph requires that the following be submitted prior to burial: a burial permit and a copy of a cremation certificate along with a copy of the Death Certificate if out-of-state or by private arrangements.
  - d. One full burial and one cremation burial will be allowed, or two cremation burials on one right to burial space.
  - e. The in-ground Cremation Section is reserved for one cremation burial per burial space only.
49. Placement of Memorial. Placement of a memorial marker for cremated remains requires the following:
- f. Own grave space.
  - g. The appropriate charges, including foundation fee, must be paid.
  - h. Memorials will not be allowed unless the regulations are satisfied.

## **COLUMBARIUM**

50. Columbarium. An alternative to in-ground burial following cremation.
- i. All columbarium burials must be conducted by cemetery personnel.
  - j. All columbarium burials will be conducted during established burial hours.

- k. All fees for columbarium burials will be paid in accordance with the Cemetery Fee Schedule, as established by the Cemetery Board. This will include columbarium charge and burial charges.
- l. The use of outside burial container (vault) is optional.
- m. A typical columbarium niche has an inside measurement of 12" x 12" x12"; depending on the size of the cremation urn, one (1) or two (2) cremation urns may fit inside a columbarium niche.

### **IMPROVEMENTS, FLOWERS AND DECORATIONS**

51. General. The Cemetery Board has developed the following standards for improvements, flowers and other decorations to grave sites and columbaria to allow for the greatest and most efficient maintenance of the cemeteries by personnel.

- n. No improvement, planters, or flowers will be permitted to any lot until the Right to Burial Certificate has been issued.
- o. The City of St. Joseph assumes no obligation as to the care, maintenance, protection, or damage which may result to improvements, planters, flowers or other decorations.
- p. The Cemetery Department will not be responsible for removing or filling dirt in flower urns, pots or other containers.
- q. No glass containers may be used.
- r. Riverview Cemetery and the City Cemetery will furnish water for the use of all who wish to maintain flowers, planters, urns, and other items. Water will be furnished and available from the various outlets within the cemeteries' grounds from May 1 to October 31 annually.
- s. Items which are left untended for more than one year will be disposed of by cemetery personnel.

52. Lot Improvements. Planting or landscape improvements are allowed only by consent of the Superintendent of Parks and Grounds. All improvements are to be placed at the head of graves only. When in doubt about any planting or improvement, check with the Superintendent of Parks and Grounds before proceeding.

- t. There shall be no planting of flowers in the Grass Marker sections (tower and cremation sections).
- u. Monument Sections – Planting of flowers is allowed in front of head stones, but in no event, may not exceed eight (8) inches from the head stone foundation.
- v. Cemetery personnel are not responsible for the care and maintenance of plantings and/or landscape improvements; untended plantings that have been allowed to wilt/wither, will be disposed of by cemetery personnel.

53. Concrete Planters. All concrete planters placed in city cemeteries must be of conventional

planter type and style, and all such planters, which are of a permanent or semi-permanent type must be placed upon a base. The base is to be placed upon the lot in such a location as approved by cemetery personnel.

- w. No more than one concrete planter will be allowed on a single grave space.
- x. No concrete planters or concrete pots are allowed in Grass Marker sections.
- y. Concrete planters are the sole responsibility of the lot owners and the City of St. Joseph assumes no responsibility for maintenance or repair of concrete planters.
- z. Planters not filled by June 15th of each year will be picked up. If not claimed within one year, they will be discarded.

54. Flowers, Wreaths and Decorations. Generally, summer and fall items may be placed from May 1 through October 31; winter items may be placed from December 1 through April 1. For maintenance purposes, no items may be placed in April or November of any year. Any unclaimed items will be considered unwanted, and be removed by cemetery personnel.

- aa. All Columbarium flower arrangements are to be placed in the designated area.
- bb. Cut flowers may be placed on head stones.
- cc. Shepherd hooks are allowed, but will be removed from grounds if unused for any period of time.
- dd. All artificial flowers must be placed in approved urns or containers. All artificial flowers not in approved urns or containers will be removed. Cemetery personnel will not be responsible for artificial flowers that may interfere with necessary grounds care activities.
- ee. Statues, figurines etc., may be allowed in lieu of planters, urns, or wreaths, upon approval of the Superintendent of Parks and Grounds. Such statues/figurines may not exceed the height of the head stone.
- ff. No religious symbols are allowed; except for those permanently engraved or attached to monuments/head stones.

55. Removal of Plants and Shrubs. Cemetery personnel shall have the right to remove, without notice, trees, shrubs and flowers planted in violation of these rules. The City of St. Joseph reserves the right to trim, cut down and remove any planting by a lot owner which are undesirable in their present condition.